

ProThermetic Sprint Electric Tilting Boiling Pan, 200lt Hygienic Profile, Freestanding

ITEM # _____

MODEL # _____

NAME # _____

SIS # _____

AIA # _____

586922 (PBOT20EDES)

Electric tilting Boiling Pan 200lt (h), auto. H/C water filling with swivelling arm, spray gun, rear closing kit, GuideYou Panel, freestanding

586947 (PBOT20EQES)

Electric tilting Boiling Pan 200lt (h), splashback, auto. H/C water filling with swivelling arm, spray gun, rear closing kit, GuideYou Panel, freestanding

Short Form Specification

Item No. _____

AISI 304 stainless steel construction. Deep drawn vessel in AISI 316 stainless steel. Insulated and counterbalanced lid. Motorized tilting with variable speed control. Pan can be tilted beyond 90° to completely empty the food. Food is uniformly heated via the base and the side walls by an indirect heating system using saturated steam at a maximum temperature of 125°C, generated in the double jacket, equipped with an automatic deaeration system. Safety valve avoids steam overpressure and safety thermostat protects against low water level in the double jacket. TOUCH control panel. GuideYou Panel easily guides the user during multiphase recipes. Built in temperature sensors for precise control of cooking process. Machine configuration including swivel arm with automatic water filling, spray gun and rear closing panel. IPX6 water resistant. Installation: Free-standing or Standing against a wall. Installation options (not included): floor mounted on 200mm high feet or a plinth which can be either steel or masonry construction. Dedicated model equipped with splashback as standard. Connectivity available.

Main Features

- Kettle is suitable to boil, steam, poach, pan fry or simmer all kinds of produce.
- Delivered with:
 - swivel arm with automatic hot/cold water filling
 - spray gun
 - rear closing panel
 - C-board (backsplash for the relevant model)
- Motorized, variable pan tilting with "SOFT STOP". Tilting and pouring speeds can be precisely adjusted. Pan can be tilted over 90° to facilitate pouring and cleaning operations.
- Kettle is jacketed up to 159 mm from upper rim.
- Built in temperature sensor to precisely control the cooking process.
- Ergonomic vessel dimensions, with a large diameter and shallow depth facilitates stirring and gentle food handling.
- Isolated upper well rim avoids risk of harm for the user.
- Edge of the large pouring lip can be equipped with a strainer (option).
- USB connection to easily update the software, upload/download recipes and download HACCP data.
- Connectivity ready, to connected appliances from remote via cable and data monitoring, including HACCP (requires optional accessory).
- IPX6 water resistant.
- Max pressure of inner jacket at 1.7 bar; minimum working pressure at 1 bar. Allows temperature control between 50 and 110°C.

Construction

- Cooking vessel in 1.4435 (AISI 316L) stainless steel featuring directional pouring lip. Double-jacket in 1.4404 (AISI 316L) stainless steel designed to operate at a pressure of 1.5 bar.
- External panelling and internal frame made of 1.4301 (AISI 304) stainless steel.
- Minimised presence of narrow gaps for easier cleaning of the sides to meet the highest hygiene standards.
- Double-lined insulated lid in 1.4301 (AISI 304) stainless steel mounted on the cross beam of the unit, counterbalanced by a hinge that remains open in all positions.
- Highly-visible and bright led TOUCH control panel features user-friendly icons and intuitive self-explanatory command options. Display visualizes:
 - Actual and set temperature
 - Set and remaining cooking time
 - Pre-heating phase (if activated)
 - GuideYou Panel (if activated)
 - Deferred start
 - Soft Function to reach the target temperature smoothly
 - 9 Power Control levels from simmering to fierce boiling
 - Pressure mode (in pressure models)
 - Stirrer ON/OFF settings (in round boiling models)
 - Error codes for quick trouble-shooting
 - Maintenance reminders

APPROVAL: _____

- Possibility to store recipes in single or multiphase cooking process, with different temperature settings.
 - GuideYou Panel - activated by the user via settings - to easily follow the multiphase recipes, granting a proper and controlled cooking and a better appliance optimization.
The system will provide maintenance reminders, in line with ESSENTIA program, helping the user to properly take care of the product, avoiding downtimes.
 - Safety thermostat protects against low water level in the double jacket.
 - Safety valve avoids overpressure of the steam in the double jacket.
 - Can be prearranged for energy optimisation or external surveillance systems (optional).
 - 98% recyclable by weight; packaging material free of toxic substances.
- Power Socket, TYP25, built-in, 16A/400V, IP55, black - factory fitted PNC 912472
 - Kit energy optimization and potential free contact - factory fitted PNC 912737
 - Rear closing kit for tilting units - island type - factory fitted PNC 912746
 - Mainswitch 60A, 10mm² - factory fitted PNC 912774
 - Food tap 2" for tilting boiling pans (PBOT) - factory fitted PNC 912779
 - Emergency stop button - factory fitted PNC 912784
 - Connectivity kit for ProThermetic Boiling and Braising Pans ECAP - factory fitted PNC 913577

Included Accessories

- 1 of C-board (length 1400mm) for tilting units - factory fitted (only for 586947) PNC 912186
- 1 of Rear closing kit for tilting units - against wall - factory fitted PNC 912706
- 1 of Automatic water filling (hot and cold) for tilting units - to be ordered with water mixer - factory fitted PNC 912735
- 1 of Spray gun for tilting units - freestanding (height 700mm) - factory fitted PNC 912776

Optional Accessories

- Strainer for 200lt round tilting boiling pans PNC 910005
- Basket for 200lt round boiling pans (diam. 760mm) PNC 910025
- Base plate for 200lt boiling pans PNC 910035
- Measuring rod for 200lt tilting boiling pans PNC 910046
- Strainer for dumplings for 200lt tilting boiling pans PNC 910056
- Scraper for dumpling strainer for boiling and braising pans PNC 910058
- Food tap strainer rod for stationary round boiling pans PNC 910162
- Bottom plate with 2 feet, 200mm for tilting units (height 700mm) - factory fitted PNC 911475
- Stainless steel plinth for tilting units - against wall - factory fitted PNC 911812
- FOOD TAP STRAINER - PBOT PNC 911966
- MOBILE KIT TxxT/PxxT (VAR.width=S-Code) PNC 912460
- Power Socket, CEE16, built-in, 16A/400V, IP67, red-white - factory fitted PNC 912468
- Power Socket, CEE32, built-in, 32A/400V, IP67, red-white - factory fitted PNC 912469
- Power Socket, SCHUKO, built-in, 16A/230V, IP68, blue-white - factory fitted PNC 912470
- Power Socket, TYP23, built-in, 16A/230V, IP55, black - factory fitted PNC 912471

Front

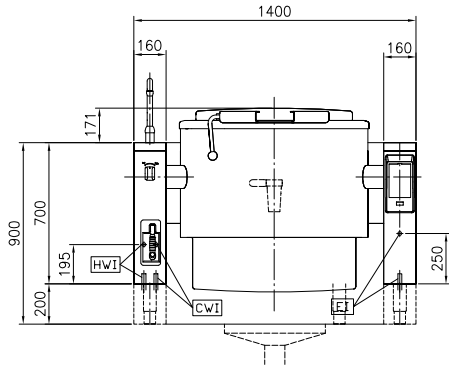

Side

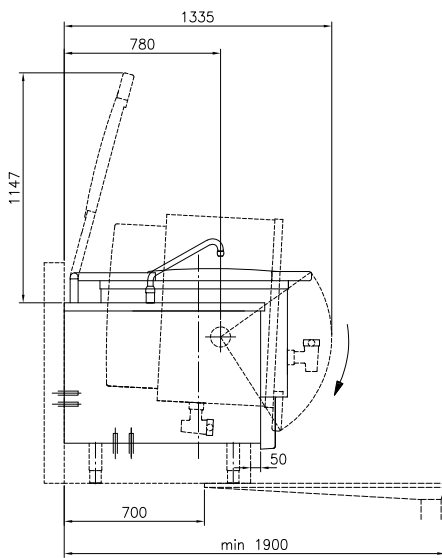

- CWI = Cold Water inlet 1 (cleaning)
- EI = Electrical inlet (power)
- HWI = Hot water inlet

Top

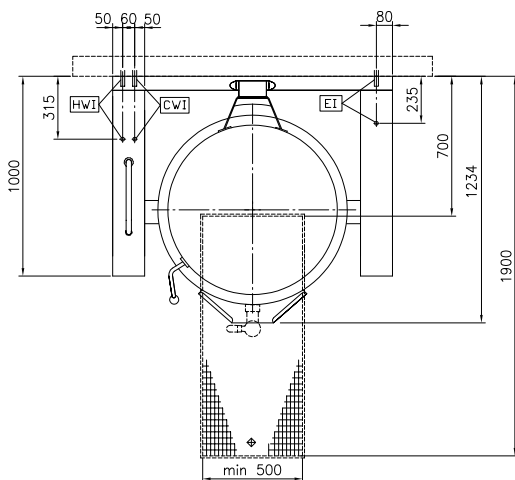

Front

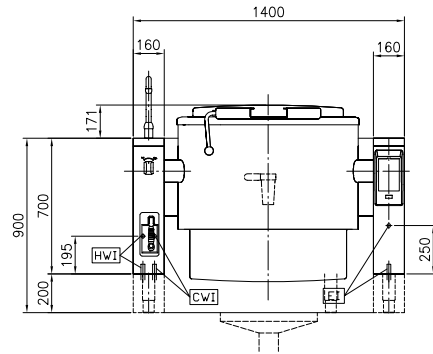

Side

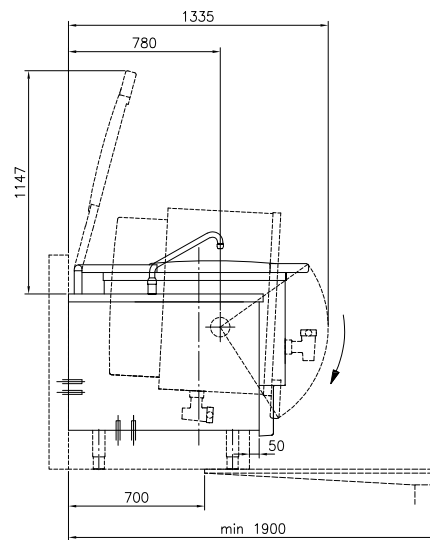

- CWI = Cold Water inlet 1 (cleaning)
- EI = Electrical inlet (power)
- HWI = Hot water inlet

Top

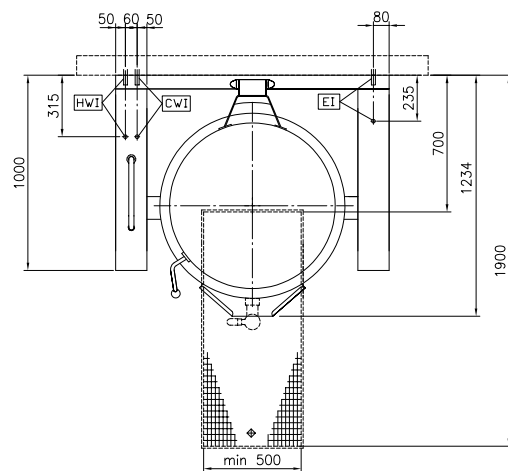

Electric

Supply voltage: 400 V/3N ph/50/60 Hz
Total Watts: 30.2 kW

Installation:

Type of installation: FS on concrete base;FS on feet;On base;Standing against wall

Key Information:

Working Temperature MIN: 50 °C
Working Temperature MAX: 110 °C
Vessel (round) diameter: 800 mm
Vessel (round) depth: 490 mm
External dimensions, Width: 1400 mm
External dimensions, Depth: 1000 mm
External dimensions, Height: 700 mm
Net weight: 360 kg
Configuration:
586922 (PBOT20EDES) Round;Tilting
586947 (PBOT20EQES) Round;Tilting;With splashback
Net vessel useful capacity: 200 lt
Tilting mechanism: Automatic
Double jacketed lid: ✓
Heating type: Indirect